

# 87R-4P Compressed Air System

Operation & Maintenance Manual



**JUN-AIR**<sup>®</sup>  
A UNIT OF IDEX CORPORATION

# ! WARNING



**PLEASE READ THIS MANUAL COMPLETELY BEFORE INSTALLING AND USING THIS PRODUCT. SAVE THIS MANUAL FOR FUTURE REFERENCE AND KEEP IN THE VICINITY OF THE PRODUCT.**

Dear Customer:

Congratulations on the purchase of your new JUN-AIR Industrial Compressed Air System. This system's intended purpose is for industrial and laboratory compression applications. It is to be used in accordance with UL1450/CSA 22.2 standards, along with all applicable codes. The system utilizes an oil-less rocking piston compressor that produces clean, dry, oil-free pressurized air flow when connected to an industrial or laboratory device. The tank ensures that a constant supply of air is available to the device.

A pressure regulator and safety relief valve are also included to ensure safe operation of the system. This manual provides installation, operation and preventative maintenance guidelines that should be followed to ensure correct/reliable performance of this system.

Please carry out all maintenance according to relevant instructions.

## Example of CE Certification

<b>GAST</b> JUN-AIR®		<b>IDEX</b> HEALTH & SCIENCE	
<b>CE DECLARATION OF CONFORMITY</b>			
<b>Models:</b>			
85R637-4P-N400X 85R637-4P-N401X	87R637-4P1-N470X 87R637-4P2-N470X	87R637-4P3A-N471X 87R637-4P3-N471X	
<p>The models listed above produced by JUN-AIR in Benton Harbor, Michigan, have been assessed for and found to be in compliance with the essential requirements of the European Directives listed below. Note: Control systems are the responsibility of the customer. This declaration encompasses air compressors, basic, and cabinet models which utilize these compressors. These machines must not be put into service until the machinery into which they have been incorporated has been declared in conformity with the appropriate EU directives. All other requirements placed on the product as designed for its intended use are specified in the customer's requirements for the equipment and are the sole responsibility of the customer and the end user of the product as it is applied per the Machinery Directive. Only products marked CE are covered by this declaration.</p>			
<b>Relevant Directives and Standards:</b>			
2014/68/EU	Pressure Equipment Directive		
2006/42/EC	Machinery Directive		
EN 1012-1 2010	Compressors and vacuum pumps. Air compressors		
EN 60204-1 2006+A1:2009	Safety of Machinery. Electrical equipment of machines		
EN 60034-1 2010	Rotating Electrical Machines, Rating and Performance		
EN 60034-5 2006	Classification of Degree of Protection		
EN 60034-11 2004	Thermal Protection of Rotating Electrical Machines		
2014/30/EU	EMC Directive		
EN 61000-6-3 2007+A1:2011	Electromagnetic Compatibility - Generic Standards		
EN 55011:2009/A1:2010	Industrial, Scientific, and Medical Equipment		
EN 61000-3-2:2006+A1:2009+A2:2009	Limits for Harmonic Current Emissions		
EN 61000-3-3	Limitation of Voltage Changes, Voltage Fluctuations and Flicker		
2011/65/EU	Restriction of Hazardous Substances (RoHS2) Directive		
Darren Coulson May 31, 2017 Assessing Engineer Gast/Jun-Air Redditch B98 7AS UK		Mike Douglass May 31, 2017 Regulatory and Compliance Engineer Gast/Jun-Air Benton Harbor, Michigan USA	
DOC1071-revA	May 31, 2017	RO 5312017	

## Example of Model Label

<b>JUN-AIR®</b> www.jun-air.com	
ITEM:	YEAR:
DESC:	S/N
VOLT:	
CURRENT:	
<b>JUN-AIR®</b> <b>CE</b>	
Gast Manufacturing, Inc A Unit of IDEX Corporation 2300 M-139, Benton Harbor, MI 49023 Tel: (269) 926-6171 Made in US of foreign and domestic parts	

## Section

## Page Number

Declaration of Conformity	2
Table of Symbols	3
System Features	4
Installation and Operation	6
Maintenance	10
Troubleshooting	21
Warranty Policy	22

**TABLE OF SYMBOLS**

 **DANGER:** Indicates an imminently hazardous situation which **will** result in serious or fatal injury if not avoided. This symbol is used only in the most extreme conditions.

 **WARNING:** Indicates a potentially hazardous situation which **could** result in serious injury if not avoided.

 **CAUTION:** Indicates a potentially hazardous situation which **may** result in minor or moderate injury if not avoided. It may also be used to alert against unsafe practices.

 Indicates the acceptable lowest barometric pressure conditions in which this unit can be shipped.

 Indicates package should be handled with these symbols pointing up.

 **FRAGILE:** Handle package with care.

 Indicates this package must be kept dry.

**INDUSTRIAL ELECTRICAL EQUIPMENT**  
With respect to electrical shock, fire, mechanical, and other specified hazards only in accordance with UL1450.

 **Electrical Shock Hazard.**  
Risk of electric shock present. Make sure power is disconnected before attempting this procedure.







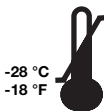

 **Equipment Alert:** Indicates a potentially hazardous situation that could result in equipment damage if not avoided.

 **WARNING: To Avoid Serious Burns.**  
Do not touch surface during operation.

 **ON OFF** Indicates the ON and OFF position for the equipment power switch.

 Indicates the acceptable maximum relative humidity for shipping.

 Indicates the acceptable shipping temperature range.

Symbol	Description
	A/C power
	Air outlet port
	Fuse location
	Ground
	Hour meter
	Over-temp indicator light
	Power on indicator light
	Pressure gauge
	Pressure regulator valve

SYSTEM FEATURES

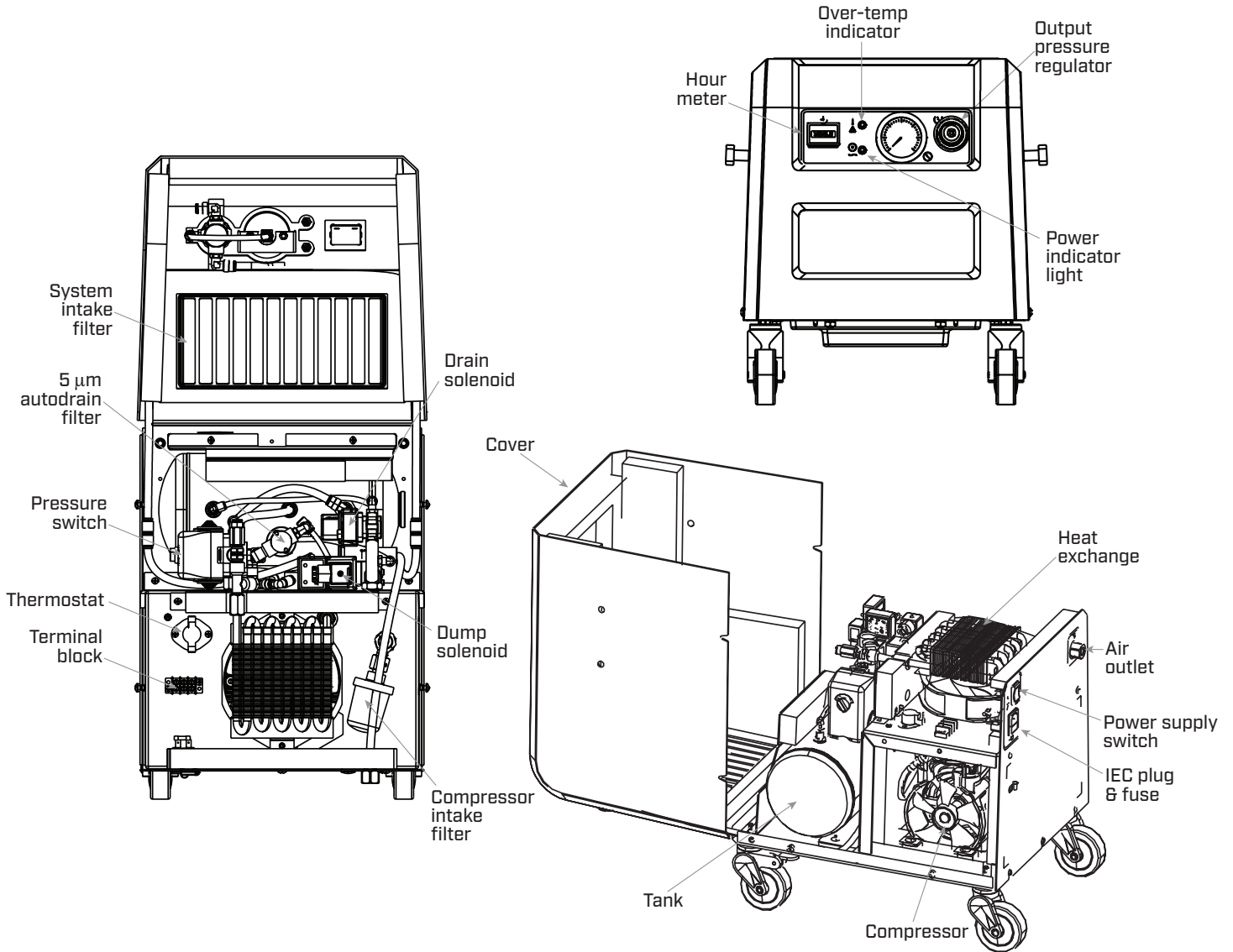

Standard 87R-4P shown.

\*Optional membrane dryer configuration available; consult factory.

Specifications	NO DRYER					
	100V		115V		230V	
	50Hz	60Hz	50Hz	60Hz	50Hz	60Hz
<b>Model Numbers</b>	1770018		1770008		1770009 (NA) 1770010 (EU/UK)	
Continuous System Output Flow @ 4 bar [58 psi]	46 SLPM [1.6 SCFM]	51 SLPM [1.8 SCFM]	46 SLPM [1.6 SCFM]	51 SLPM [1.8 SCFM]	46 SLPM [1.6 SCFM]	51 SLPM [1.8 SCFM]
Continuous System Output Flow @ 8 bar [116 psi]	27 SLPM [1.0 SCFM]	31 SLPM [1.1 SCFM]	27 SLPM [1.0 SCFM]	31 SLPM [1.1 SCFM]	27 SLPM [1.0 SCFM]	31 SLPM [1.1 SCFM]
Cut-in Pressure <sup>1</sup>	6 bar [87 psi]					
Cut-out Pressure <sup>1</sup>	8 bar [116 psi]					
Maximum Operational Pressure	8 bar [116 psi]					
Dew Point Suppression <sup>2</sup>	(>10 °C with optional membrane dryer)					
Air Filtration	5 µm					
Safety Relief Valve Pressure	9.3 bar [135 psi]					
High Temperature Indication	≥ 60 °C [140 °F] in compressor chamber					
Air Connections	1/4 in BSPP					
Current, A	5.0	5.8	4.8	5.3	2.6	2.9
Power Consumption, W	450	550	500	600	550	650
Fuse Specifications	12.5 A, 250 Vac, time delay					
Sound Level, dB(A)	46	48	46	48	46	48
Operating Ambient Conditions	10 °C to 40 °C [50 °F to 104 °F] 10 - 95% RH*					
Storage Ambient Conditions	-28 °C to 65 °C [-18 °F to 149 °F] 10 - 95% RH* Barometric pressure ≥372 mm-Hg [14.7 in-Hg]					
System Dimensions W x H x D	406 mm x 495 mm x 439 mm [16 in W x 19.5 in D x 17.3 in H]					
System Weight	29.5 kg [65 lb]					
Shipping Weight	35.0 kg [77 lb]					
Regulatory Certifications	UL 1450 / CSA 22.2 / CE					

<sup>1</sup>The compressor switches on and off at the cut-in and cut-out pressures, respectively. The cut-in and cut-out pressures are adjustable.

<sup>2</sup>Membrane dryer configuration available, consult factory.

\* Avoid conditions that promote condensation on the equipment.

## INSTALLATION AND OPERATION

### Intended Use

To provide compressed air for use with industrial or laboratory devices as a primary or back-up air source.

JUN-AIR compressor systems meet or exceed the most current and highest safety standards, which are:

- UL1450, 4th edition
- CSA C22.2 68
- ISO 9001:2008
- Ingress protection: IP50
- 2006 / 42 / EC Directive
- RoHS compliant

To ensure the safety potential of this equipment is achieved, please:

Make sure your equipment is installed according to the instructions provided in this manual and make sure the installation checklist is completed prior to starting the equipment.

#### DANGER

The equipment is not suitable for use in the presence of a flammable anesthetic mixture or with oxygen or nitrous oxide. **DO NOT OPERATE THE EQUIPMENT IF THESE CONDITIONS EXIST.**

### Transportation and Storage Conditions

- Temperature: -28 °C (-18 °F) to 65 °C (149 °F)
- Relative humidity: 10% to 95%
- Minimum barometric pressure: 372 mm•Hg (14.7 in•Hg)
- Keep the system dry at all times.
- Do not stack units during shipment, installation, or usage.



Equipment Alert: Refer servicing to an authorized service representative.

### Unpacking

1. Cut the banding strap from the carton and remove the lid and cardboard inserts.
2. Visually inspect the entire system for shipping damage and verify that the following accessories have been included: two (2) locking casters, two (2) non-locking casters, four (4) vibration-isolation feet, four (4) studs, four (4) washers, and one (1) power cable.
  - a. If the contents were damaged during shipping, contact the freight carrier to file a claim.
  - b. If parts are missing, contact the supplier.
3. Use caution when removing the system from the remaining packaging. Retain the packaging material for future use, if necessary.
4. Install the casters or rubber mounting feet.

### Before You Install...



Equipment Alert: Compressors are oil-less and require NO lubrication.



Equipment Alert: The system must be installed in a temperature-controlled and/or ventilated room to ensure operational ambient temperature of 50 °F to 104 °F [10 °C to 40 °C]. A 12-inch clearance is required on each side and top of unit to allow air flow. Failure to do so could cause premature loss of system performance and void warranty.

### Personal Safety

#### DANGER

Risk of fire or explosion when using flammable substances. Do not operate the system in an area containing combustible gases or anesthetic mixtures.

#### CAUTION

Never leave children unattended near the system when in use.

#### WARNING

Property damage and/or personal injury may result if directions are not followed or if the manufacturer's replacement parts/accessories are not used.

#### WARNING

Only connect equipment suitable for the listed maximum pressure of the system.

**⚠ WARNING**

DO NOT install the system on a surface with an incline that exceeds 10°.

**⚠ WARNING**

If unit is operating at a high altitude, adjustments to the duty cycle (on time) or operating pressure may be required. Consult a service technician prior to making any adjustments.

**⚠ WARNING**

A leaking pressure relief valve may indicate a need for adjustment or repair. Consult a service technician prior to making any adjustments.

**Protection Against Electrical Shock**

Provide proper grounding per NFPA 70 (NEC 2008). Do not create a current path from the equipment to ground through your body.

**Electrical Safety**

- Verify that the voltage and frequency specified on the system are the same as that of the supply power.
- Never operate unit outside the specified voltage range (see “SITE REQUIREMENTS” for range).
- See “SPECIFICATIONS” for more electrical information.
- Indicator light on the system cover displays when system power is supplied and power switch is on.

**Electromagnetic Interference (EMI):**

The JUN-AIR system is designed to avoid electromagnetic emissions interference with surrounding electrical equipment. Due to the vast assortment of electrical equipment available, it is possible that some interference may be experienced by the end customer. If interference is experienced, the device that is creating interference should be removed from the room where the compressor system is located. If the interference persists, then it may be necessary to confirm that both devices are connected to isolated (separated) circuits per “ELECTRICAL CONNECTIONS” in this manual. If the problem still occurs, then the two devices should be moved as far apart as possible. Finally, if the problem cannot be eliminated, contact JUN-AIR.

**⚠ CAUTION**

Routinely inspect any and all power cords for cuts and abrasions. Discontinue use and have an authorized service representative replace cord if damaged.

**⚠ WARNING**

Use of an extension cord is not advisable. An undersized extension cord will cause a drop in line voltage and loss of power. Overheating may result. Death or fire from electrical shock could occur.

**⚠ WARNING**

Electric shock could occur as a result of improper grounding. This product must be grounded according to NEC regulations and all local codes

**⚠ WARNING**

Always switch system off and remove power when servicing or removing the electrical cover. Lock out power at the breaker prior to servicing.

**⚠ CAUTION**

Do not plug into an ungrounded outlet or adapter. Reliable earth ground can only be achieved when system is connected to a grounded receptacle.



**WARNING: To Avoid Serious Burns,** do not touch surface during operation and allow it to cool prior to servicing.

**⚠ WARNING****Electrical Shock Hazard**

The grounding wire is indicated by green insulation or green insulation with yellow stripes.

Install this product in a dry location.

Install this product where it will be weather protected.

This product must be properly grounded. Electrically ground this product per local codes.

Check the condition of the power supply wiring.

Do not permanently connect this product to wiring that is not in good condition or is inadequate for the requirements of this product.

Follow all local applied codes prior to installation.

**Failure to follow these instructions can result in death, fire, or electrical shock.**

## Site Requirements

Specifications	100 V 50-60 Hz	115 V 50-60 Hz	230 V 50-60 Hz
<b>Electrical</b>			
Voltage min./max.	90/110	103/127	207/253
Full load amps (50 Hz)	5.0	4.8	2.6
Full load amps (60 Hz)	5.8	5.3	2.9

## Placement

- The system is intended only for indoor use in a climate-controlled and dust-free environment.
- Do NOT install/operate the system in an enclosed area where the ambient temperature could fall below 10 °C (50 °F) or rise above 40 °C (104 °F).
- Maintain a minimum clearance of 30 cm (12 in) on the top and sides of the system for service access and cooling.
- Ensure that the system is placed on a surface with an incline that does not exceed 10°.



Indicates the **ON** and **OFF** position for the equipment power switch (system breaker)



When **ON**, the indicator light will illuminate and current **WILL** be supplied to system.

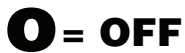

When **OFF**, the indicator light will NOT illuminate and current **WILL NOT** be supplied to the system.

## Pneumatic Connections

### **WARNING**

The system should only be installed by qualified personnel in a clean, dry, well-ventilated area on a firm surface with an incline of less than 10°.



**Equipment Alert:** Verify that all leaks are sealed. Air leaks are the primary cause of premature system failures.

Connect the plumbing from the device air-inlet to the 1/4 in BSPP air-output fitting on the back panel of the system.



## Electrical Connections



**Equipment Alert:** If a replacement fuse is required, then a 12.5 A, 250 VAC resistance time-delay fuse should be used.

Refer to the specifications table for the electrical specifications of your model.

1. Remove the screw retaining the cord anchor from the back panel of the system. Place the cord anchor around the cord and secure it to the back panel using the screw provided, ensuring enough slack in the cord to connect it to the system.
2. Plug the male IEC connector on the power cord into the female connector on the back panel of the system, ensuring it is seated securely.
3. Plug the opposite end of the cord into an outlet providing the voltage and frequency required by the system, per specifications.

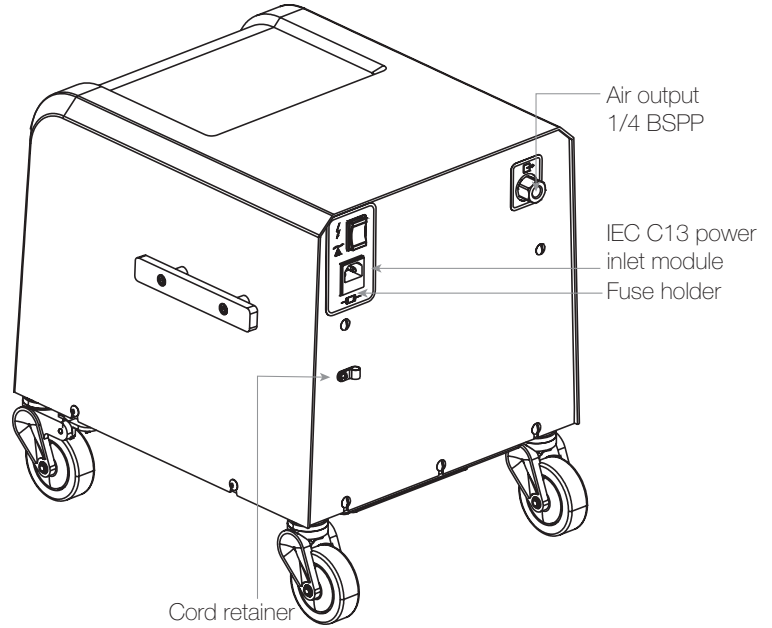

System	Voltage	Frequency	Charge Time	Recover Time	Cut-In Pressure	Cut-Out Pressure
1770008	115 V	50 Hz/60 Hz	≤55 s @ 50 Hz ≤45 s @ 60 Hz	≤30 s @ 50 Hz ≤25 s @ 60 Hz	6 bar (87 psi)	8 Bar (116 psi)
1770009	230 V					
1770010	230 V					
1770018	100 V					
1770019	115 V					

## System Checks and Tests

### WARNING

Always switch the system off and disconnect power when removing the system cover.

1. Switch the system power on and verify that the compressor runs and the storage tank begins to pressurize.
2. Check the incoming line voltage to verify that it remains within the range specified in the Site Requirements table while the system is running. If the voltage does not remain within the specified range, contact JUN-AIR.

### NOTES:

- The safety relief valve is set to 9.3 bar (135 psi).
- The pressure switch is set to cut in at 6 bar (87 psi) and cut out at 8 bar (116 psi). See the specifications table for details.
- Monitor the line-pressure gauge when testing for leaks.
- The tank pressure can be measured using the line pressure gauge by closing the system outlet and adjusting the regulator knob clockwise until it no longer turns.
- If the tank pressure drops more than 0.5 bar (7.5 psi) in three minutes, air leaks are present. Locate and repair the leak(s).
- Soapy water can be used to check for pressure leaks.

## Operation

1. When the system is completely installed and ready for operation, it can be switched on using the power switch on the back panel. A light on the front panel will turn on to indicate that power is supplied to the system and it is operational.
2. The system will provide clean, dry air and has preset cut-in and cut-out pressures of approximately 6 bar (87 psi) and 8 bar (116 psi), respectively. Check the internal tank gauge reading to verify the pressure-switch settings. Contact your authorized dealer before adjusting the cut-in/cut-out pressures to values outside the preset range.
3. The pressure of the output air can be adjusted using the regulator knob.
4. When the system is not in use, it should be turned off using the power switch on the back panel. The indicator light on the system cover will turn off when the system is powered down.

### WARNING

Discharge pressure in the tank prior to transporting the system or removing connections.

## MAINTENANCE

Performing regularly scheduled maintenance will ensure your system provides you with years of superior service. To extend your system's life, please do the following:

- Keep the system and surrounding area clean and free of debris.
- Maintain the recommended ambient temperature; high temperatures will shorten the life of the system.
- Verify that all leaks are sealed.



**Equipment Alert:** Indicates a potentially hazardous situation that could result in equipment damage if not avoided.

### WARNING



#### Electrical Shock Hazard

Disconnect electrical power supply cord before performing maintenance on this product

If product is hard wired into system, disconnect electrical power at the circuit breaker or fuse box before performing maintenance on this product.

**Failure to follow these instructions can result in death, fire, or electrical shock.**

### WARNING

#### Injury Hazard

Product surfaces become very hot during operation, allow product surfaces to cool before handling.

Air stream from product may contain solid or liquid material that can result in eye or skin damage, wear proper eye protection.

Clean this product in a well ventilated area.

**Failure to follow these instructions can result in death, fire, or electrical shock.**



**WARNING:** Always disconnect power before servicing. Surface(s) can be extremely hot depending on system usage. Do not touch hot parts during or immediately after operation.

## Cleaning or Replacing the System-Intake Filter Element

1. Turn the system off and disconnect it from electrical power.
2. Remove the intake filter element from the system cover and inspect for damage.
3. If cleaning the filter, use warm, soapy water and ensure that it is dry before reinstalling. If replacing the filter, discard the used element.
4. Install the new or cleaned filter element into the system cover, ensuring that it is fully seated the cover.
5. Reconnect electrical power to the system.

**NOTE:** Filter kits are available for the system (see PARTS AND ACCESSORIES).

## Replacing the Autodrain-Filter Element

1. Turn the system off and disconnect it from electrical power.
2. Bleed all of the air from the system.
3. Remove the handle bolts (4) and loosen the cover screws (4) to tilt the cover forward.
4. Rotate the filter bowl and drop it down slightly to remove it, using caution to avoid damaging or kinking the drain tube.
5. Remove the filter element by turning it completely out, using caution to avoid damaging the plastic element holder. Discard the used filter.
6. Install a new 5  $\mu\text{m}$  filter element after verifying that it is the correct part.
7. Position the filter bowl by pushing up slightly and rotating it into place. Verify that the drain tube is not kinked or damaged.
8. Ensure that the drain tube passes through the base plate and into the evaporator tray.
9. Replace the cover and reinstall the handle bolts and cover screws.
10. Reconnect the electrical power to the system.

## Replacing the Evaporator-Tray Element

1. Turn the system off and disconnect it from electrical power.
2. Remove the handle bolts (4) and loosen the cover screws (4) to tip the cover forward.
3. Locate the evaporator tray and remove the foam.
4. Discard the used foam, clean the tray, and install new foam.
5. Replace the cover and reinstall the handle bolts and cover screws.
6. Reconnect the system to electrical power.

## Replacing the Compressor-Intake Filter Element

1. Turn the system off and disconnect it from electrical power.
2. Remove the handle bolts (4) and loosen the cover screws (4) to tip the cover forward.
3. Remove the intake filter cap by depressing and rotating it while holding the base of the filter.
4. Remove and discard the used intake filter element.
5. Install a replacement filter element and reinstall the filter cap.
6. Replace the cover and reinstall the handle bolts and cover screws.
7. Reconnect the system to electrical power.

### **WARNING**

Disposal of system components, deemed non-usable by the authorized dealer and the end user, should be done in accordance with all local codes. Contact your local waste management authorities to determine proper disposal methods.

### **WARNING**

Do not exceed the OSHA requirements of 2 bar [29 psig] air for cleaning purposes.

## Pressure-Switch Adjustment

### **⚠ WARNING**

Exceeding the maximum pressure may result in a reduced system life. Contact Gast Manufacturing for information regarding operation at higher pressure.



**Equipment Alert:** The factory set cut-in and cut-out pressures are approximately 6 bar (87 psi) and 8 bar (116 psi), respectively.



**Equipment Alert:** The system should operate at 50% duty cycle or less.

1. Turn the system off and disconnect it from electrical power.
2. Remove the handle bolts (4) and loosen the cover screws (4) to tip the cover forward.
3. Remove the screw retaining the pressure-switch cover and remove the cover.
4. To increase the cut-in pressure, use a 7 mm wrench or socket to turn each of the two nuts on the large springs (A) clockwise; both springs should be adjusted equally. Each half-turn raises the cut-out pressure approximately 0.25 bar (3.5 psi). The cut-in pressure can be reduced by turning the springs in the opposite direction.
5. Set the cut-out pressure by adjusting the pressure differential (the difference between the cut-in and cut-out pressures). To increase the pressure differential turn the nut on the small spring (B) clockwise. Decrease the pressure differential by turning the nut counter-clockwise. Ensure that the cut-out pressure does not exceed the maximum rated pressure of the system.
6. Replace and secure the pressure-switch cover to protect against electric shock.
7. Reconnect the system power and charge the tank and verify that the compressor switches off at the desired cut-out pressure. Should the pressure reach 9.3 bar (135 psi)  $\pm 3\%$ , the safety relief valve will open and purge the tank.
8. Drain air from the system through the regulator to verify that the compressor switches on at the desired cut-in pressure.
9. Disconnect power and repeat steps 3-8, if necessary.
10. Replace the cover and reinstall the handle bolts and cover screws.
11. Reconnect the system to electrical power.

### Pressure Switch '1' on or '0' off

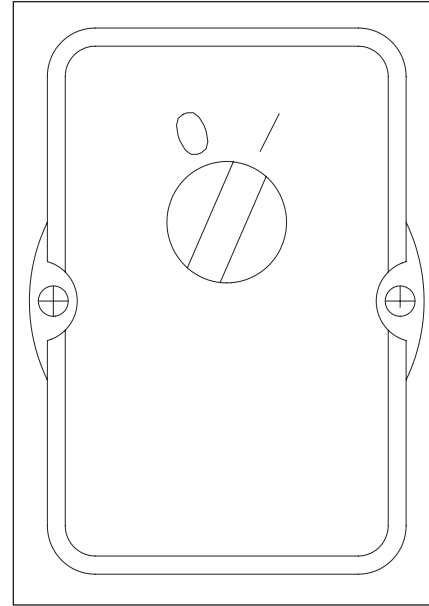

### Adjustment of Pressure Switch Section

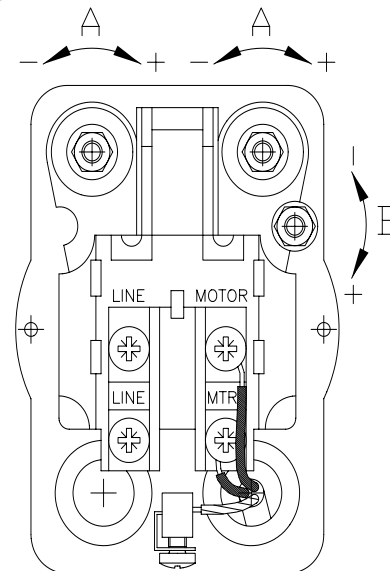

## Testing the System for Leaks

It is recommended that leak testing be performed after any maintenance or service.

1. Close the valve to the facility plumbing.
2. Run the system until it reaches the maximum operating pressure—approximately 8 bar (116 psi).
3. Turn the system off.
4. Let the system rest for five minutes.
5. If the pressure drops more than 0.5 bar (7.5 psi) within five minutes, then leaks must be repaired.
6. Use soapy water to locate leaks and repair them as necessary.
7. Open the valve to the facility plumbing.

## Preventive Maintenance Schedule

Interval	Action	P/N
Monthly	Remove and clean system-intake filter	-
Annually	Replace system-intake filter	AS562
Annually	Replace autodrain-filter element	4071009
Annually	Replace coalescing filter element in membrane dryer assembly	Consult factory
Annually	Replace compressor-intake filter element	B300A
Annually	Replace evaporator-tray foam element	AS561A
Annually	Test for air leaks	-
Annually	Inspect system for functionality using system checks and tests	-
8,000 hours	Rebuild compressor	K964

## Parts and Accessories

Part no.	Description	Kit contents
4736609	European power cord	
4736621	UK / GBR power cord	
4736620	Asian / Australian power cord	
4736915	IEC C13/C14 power cord	
4736882	US 115 V power cord	
4736931	US 230 V power cord	
AS560	Check valve	
AS620A	Filter kit (annual)	Intake filters and evaporator filter
K964	Compressor rebuild kit	O-rings, seals, cups, cylinders
AS623	Rubber-mounting-feet kit	Four (4) rubber isolation feet and washers

Model: 1770008

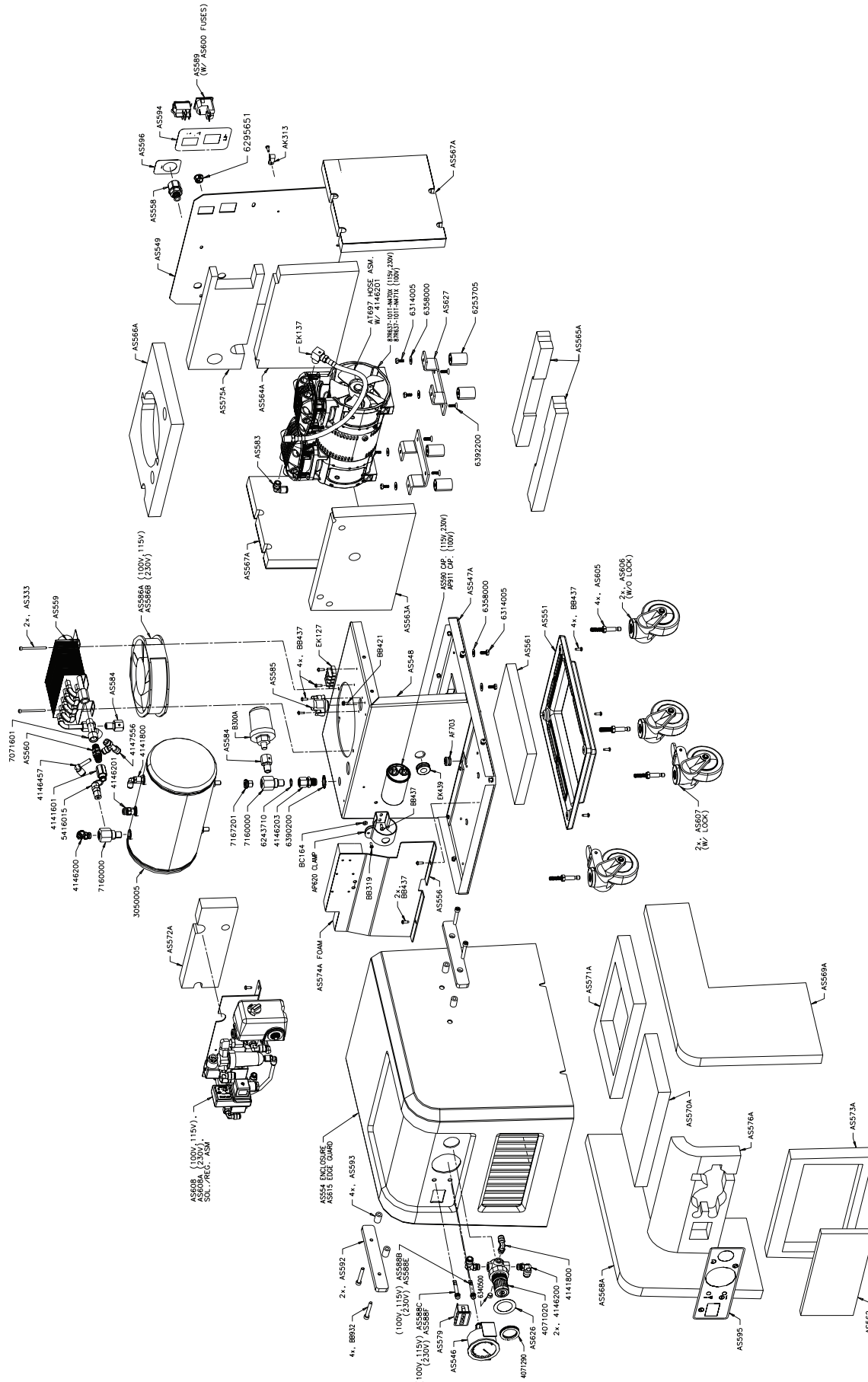

Standard 87R-4P shown.

\*Optional membrane dryer configuration available; consult factory.

Models: 1770009 & 1770010

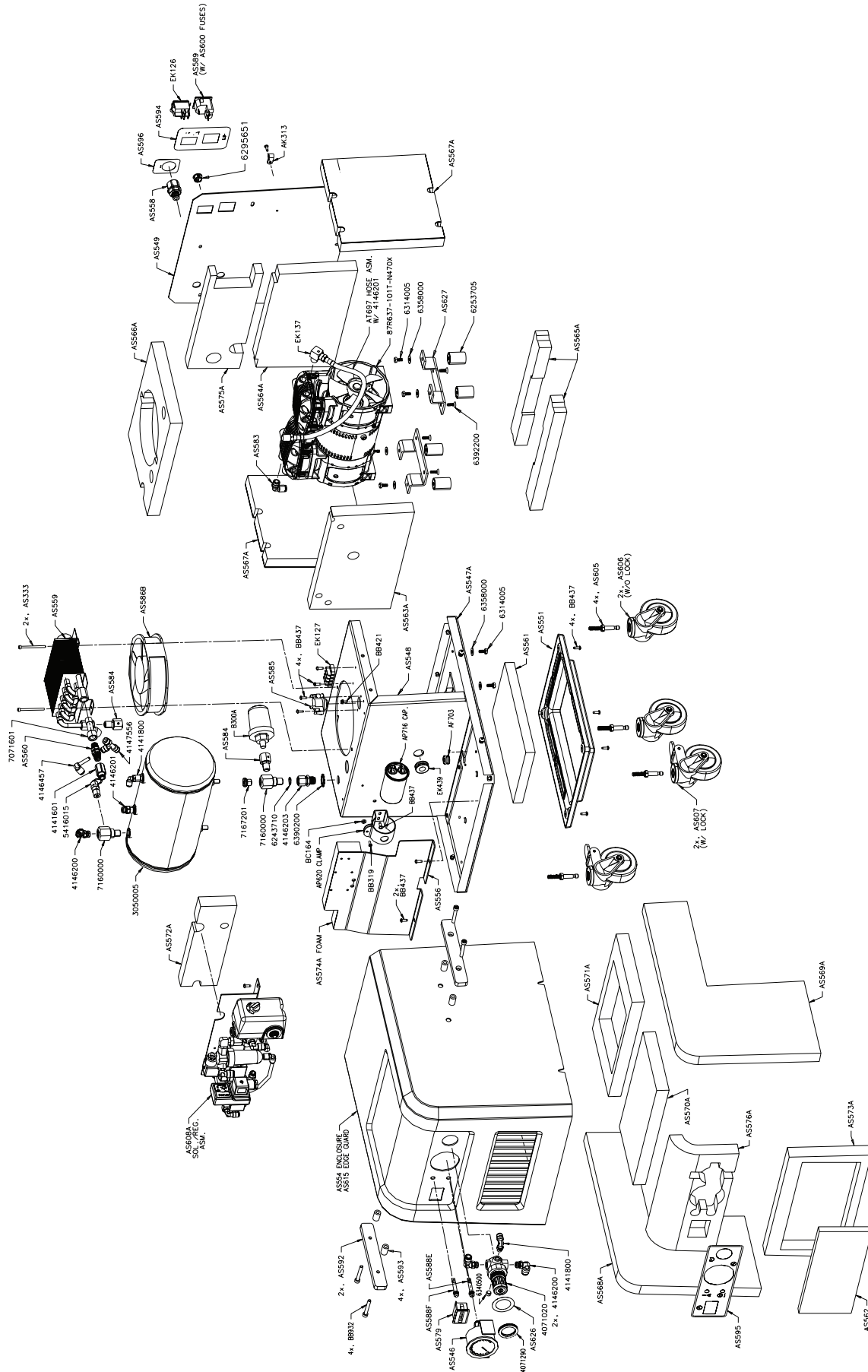



Model: 1770018

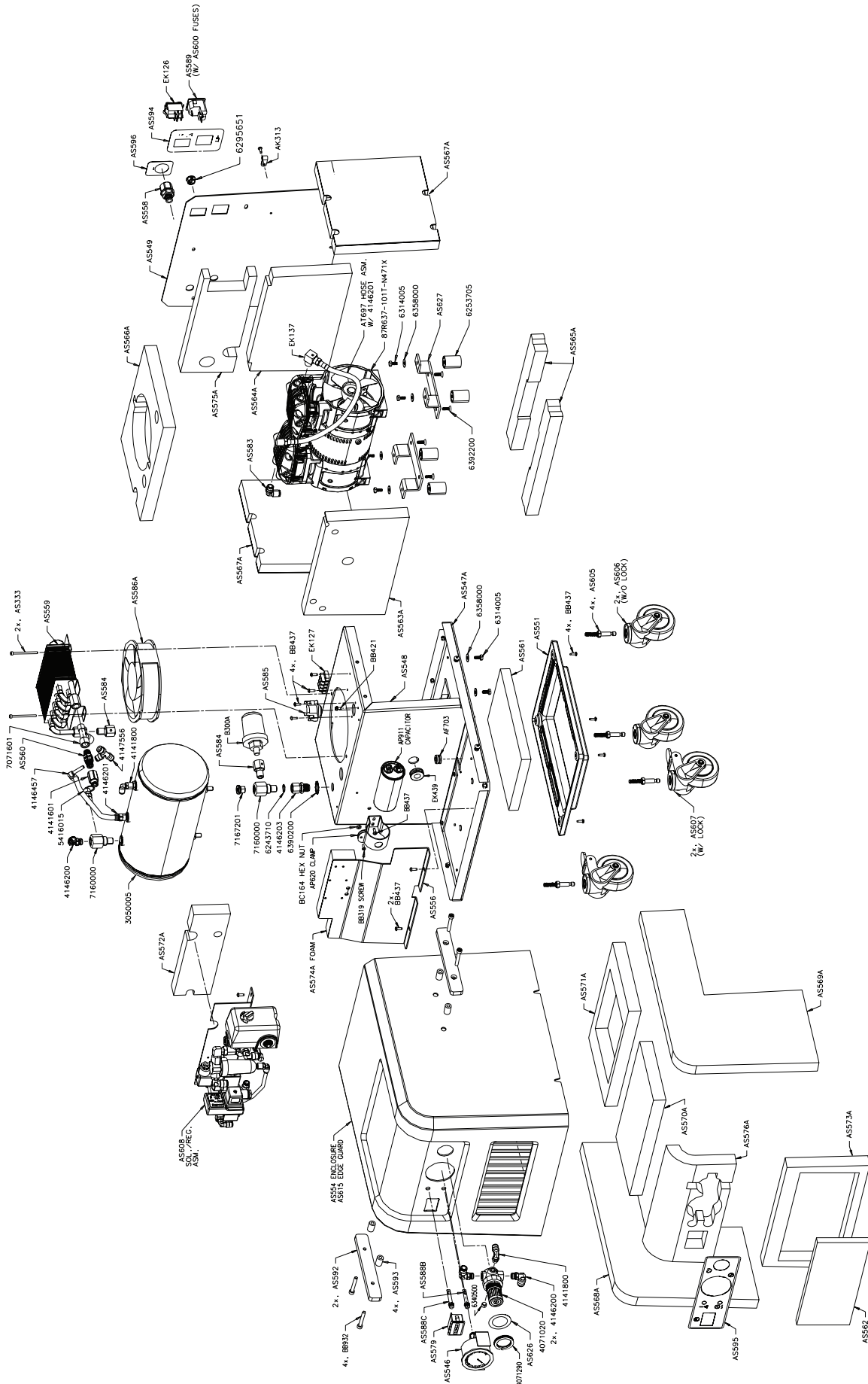

Pneumatic Schematic

**87R-4P Compressor System  
Pneumatic Schematic**

- (X) = Pneumatic Tube Connection Letter
- AS61 3"X" = 6mm OD Tubing
- AS61 4"X" = 8mm OD Tubing

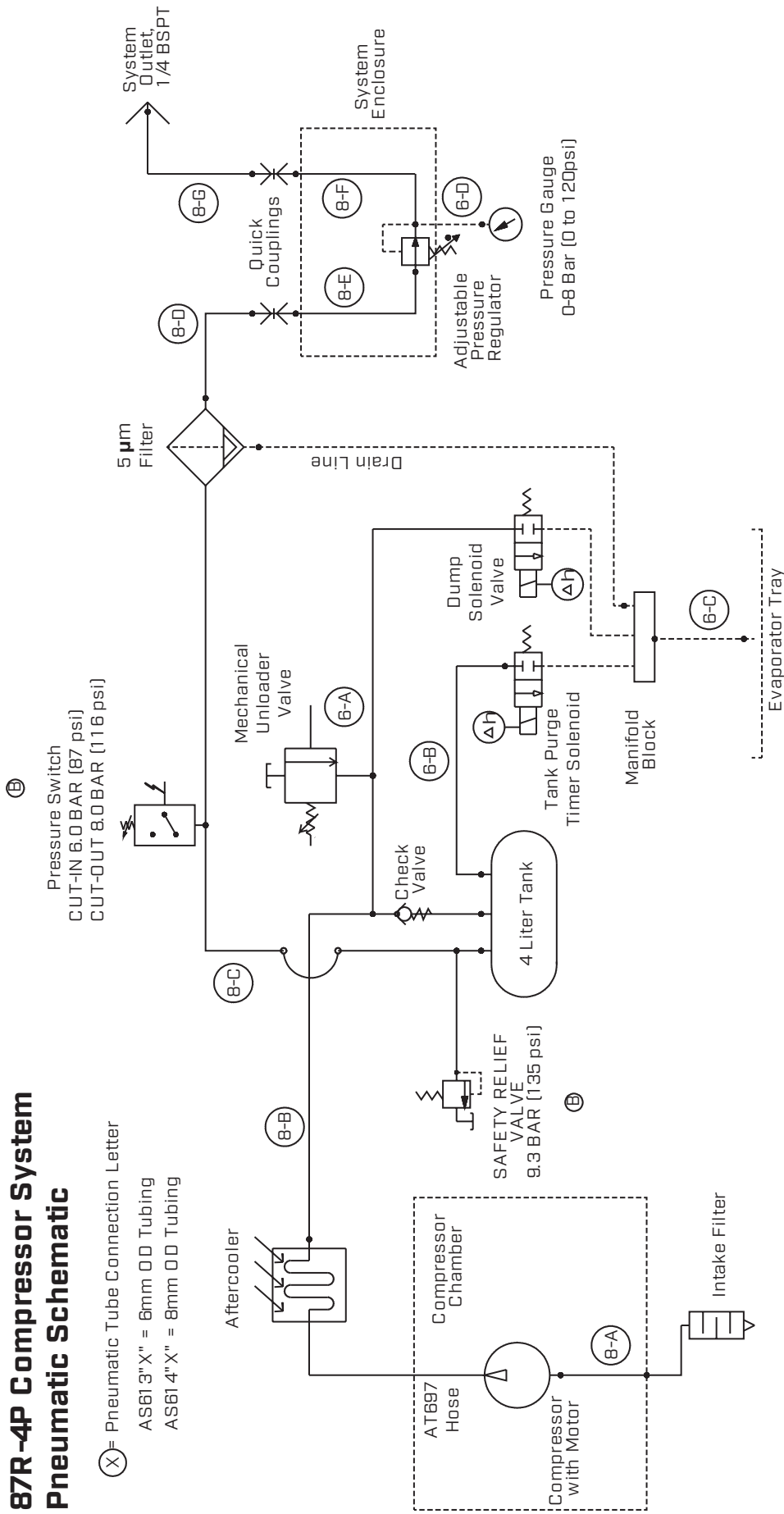

Pneumatic Schematic

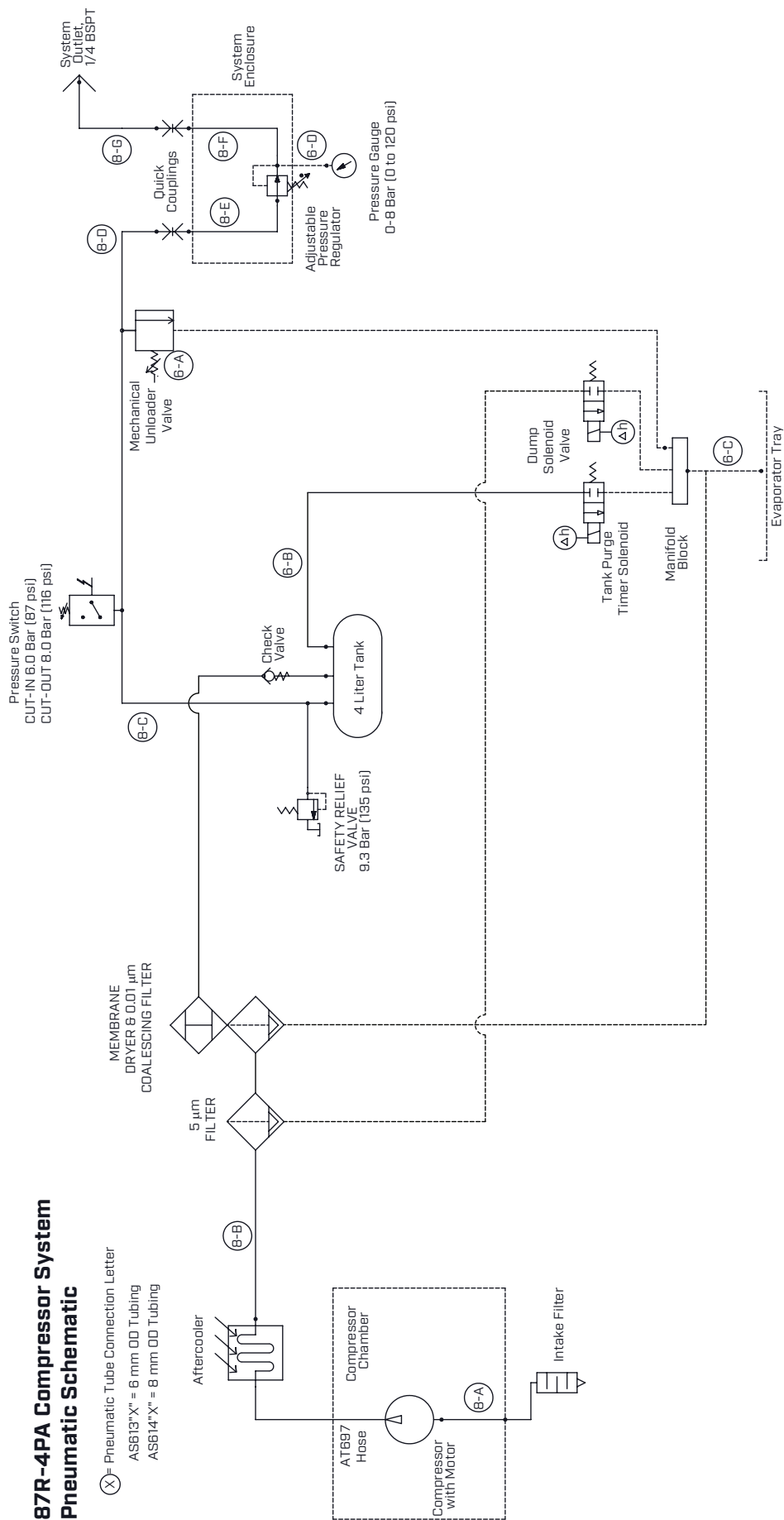

**Electrical Schematic**  
 (applies to all models)

(X) = AS580"X" Electrical Wire Reference  
 Enclosure Cover

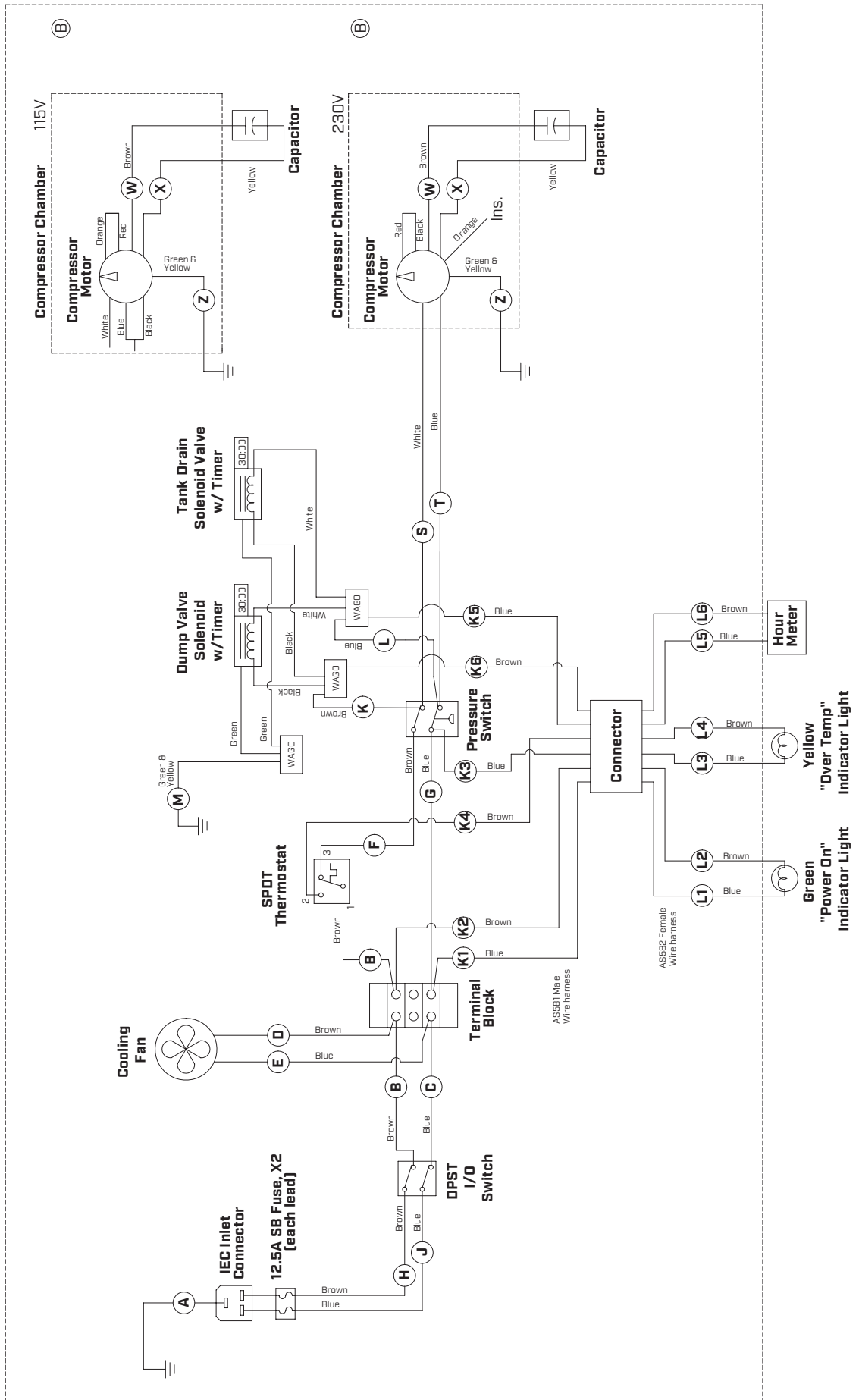

**TROUBLESHOOTING**

<b>Problem</b>	<b>Possible Cause(s)</b>	<b>Possible Solution(s)</b>
Compressor does not start	No electrical power	Check the circuit breaker at the main power source.
	Power not connected	Check the power cord at both ends.
	Power not switched on	Verify that the system power switch is in the on position.
	Defective power switch	The power switch needs to be replaced. Contact your authorized dealer for service.
	Fuse is blown or damaged	Check the fuse(s) in the electrical inlet.
Circuit breaker trips when the compressor attempts to start	Voltage is too low	The compressor requires a minimum of 103 V/207 V. If the voltage is below the minimum required, a buck-boost transformer must be installed.
	Solenoid valve does not open when the compression cycle ends	Contact an authorized dealer for service.
	Power supply cable is too small	See SITE REQUIREMENTS for the current draw for the applicable system, and select the appropriate wire gauge size.
	Loose electrical connections	Contact an authorized dealer for service.
Unusual or excessive noise	Intake filter is not seated correctly	Remove and replace the filter if it is clogged or dirty. Ensure that the filter chamber is clean and the filter is seated properly during installation.
	Intake filter(s) is clogged or dirty	Replace the filter.
	Noisy compressor	Contact an authorized dealer for service.
	Air leaks	Close the storage-tank outlet valve and check all fittings for leaks. If a leak is found, contact an authorized dealer for service.
	Cooling fan	Check for a loose or broken fan. Contact an authorized dealer for service.

(Continued on next page)

**TROUBLESHOOTING (Continued)**

<b>Problem</b>	<b>Possible Cause(s)</b>	<b>Possible Solution(s)</b>
Compressor cycles, but tank pressure does not reach 8 bar (116 psi)	Solenoid valve does not close or leaks when compressor runs	Check the solenoid valve and contact an authorized dealer for service.
	Intake filter is clogged or dirty	Replace the intake filter(s).
	Leak in the system	Close the storage-tank outlet valve and check all fittings for leaks. If a leak is detected, contact an authorized dealer for service.
	Leak in the device air system	With the compressor system connected to the device-air system and the regulator valve open, run the compressor until the cut-out pressure is reached and the compressor is switched off, and then close the regulator valve. After five minutes, open the regulator valve and observe the system pressure drop. If the pressure drop exceeds 0.5 bar (7.5 psi), there is a leak in the device air system. If a leak is detected, contact an authorized dealer for service.
	Cut-in and/or cut-out pressures are out of adjustment	Adjust the pressure switch (see MAINTENANCE).

**WARRANTY POLICY**

If, within the warranty time limits described below, the system or any of its components fail under normal use and service, the original user-owner must contact an authorized JUN-AIR dealer with the product sale and service records. Should the dealer not be able to complete the repair, the dealer may contact JUN-AIR for disposition. The product's model and serial number, the installation date, and the JUN-AIR invoice number must be furnished. Transportation charges both ways must be paid by the dealer. If, upon receipt at the factory, an examination reveals faulty or defective original parts, materials, or workmanship, JUN-AIR will, at its sole discretion, rebuild or replace. This warranty does not cover damages caused by misuse, abuse, accident, or neglect. Unauthorized alterations or repairs made outside our factory will cancel this warranty and charges for them will not be allowed.

**COMPRESSOR SYSTEMS**

All compressor systems sold and installed by authorized JUN-AIR dealers are warranted to be free from defects in parts, workmanship, and materials for 8,000 hours of operation or two (2) years from date of purchase, whichever occurs first.

This warranty excludes normal expected service items such as but not limited to: filters/filter kits, o-rings, and hoses. It also excludes add-on accessories that carry their own specific manufacturer's warranty.

## INSTALLATION CHECKLIST

---

- Check system for shipping damage
- Remove packaging cardboard
- Verify installation kit components
- Relocate unit to operating location and place per "SITE REQUIREMENTS"
- Attach pneumatic fittings and connections per "SITE REQUIREMENTS" and "PNEUMATIC CONNECTIONS".
- Attach electrical connections per "SITE REQUIREMENTS" and "ELECTRICAL CONNECTIONS" requirements
- Verify incoming line voltage meets minimum and maximum values
- Turn on power to dedicated circuit and ensure unit starts. If not, refer to "TROUBLESHOOTING GUIDE"
- Perform system checks per "SYSTEM CHECKS AND TESTS"

**Gast Manufacturing**

P.O. Box 97  
2300 M139 Highway  
Benton Harbor, MI 49023-  
0097  
Ph: 269-926-6171  
Fax: 269-925-8288

**Gast Group Limited**

**c/o IDEX Trading (Shanghai) Co., LTD**  
Room 3502-3505  
No. 1027 Chang Ning Road,  
Zhaofeng Plaza  
Shanghai, China 200050  
Phone +86-21-52415599  
Fax +86-21-52418339

**Gast Group Ltd.**

Unit 11, The I O Centre  
Nash Road  
Redditch, B98 7AS  
United Kingdom  
Phone +44 (0)1527-504040  
Fax +44 (0)1527-525262

**[www.JUN-AIR.com](http://www.JUN-AIR.com)**