



GAST MANUFACTURING, INC.
 A Unit of IDEX Corporation
 Post Office Box 97
 Benton Harbor, Michigan
 Ph: 269/926-6171
 Fax: 269/925-8288

PART NUMBER:

LTD182

REV.

C

Product Specifications

MODEL NUMBER	MOTOR SPECIFICATIONS	RPM	MAX VAC		MAX PRESS		HP	KW	NET WT.	
			"H ₂ O	mbar	"H ₂ O	mbar			lbs.	kg
R6340R-50	208-230/460-60-3	3450	80	199	100	249	4.0	3.0	112	51
	190-220/380-415-50-3	2850	65	162	75	187	3.0	2.2		

SOUND LEVEL 72/69 dB(A) MAX. @ 60/50 Hz
 NORMAL AMBIENT -29°C TO 40°C
 RELATIVE HUMIDITY 0% - 100% NON CONDENSING
 ENVIRONMENT CLEAN DUST FREE

NOTES:

1. TECHNICAL DATA SUBJECT TO CHANGE WITHOUT NOTICE.
2. WIRING DIAGRAM: SEE MOTOR.
3. UL AND CSA APPROVED MOTOR FOR EXPLOSIVE GAS ATMOSPHERES CLASS 1, GROUP D.
4. THIS BLOWER IS DESIGNED FOR SOIL AND GROUND WATER REMEDIATION.

Product Performance

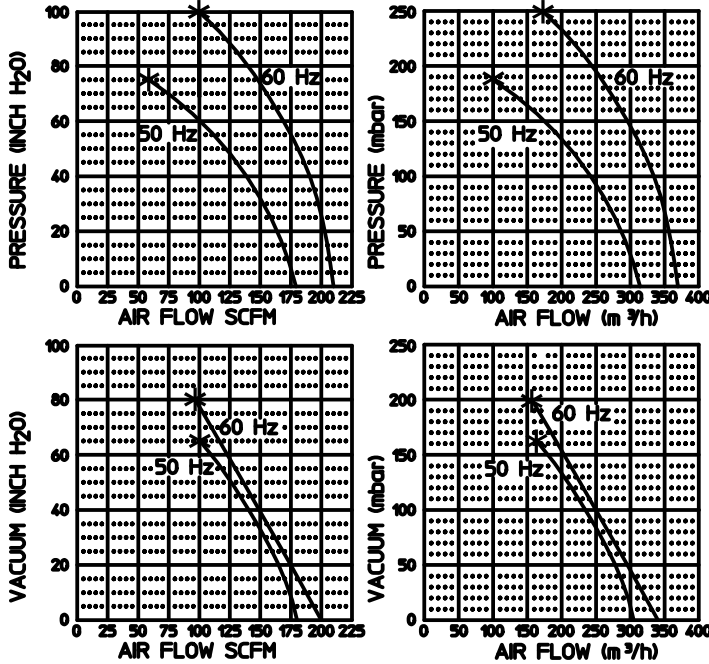

PERFORMANCE DATA

THE PERFORMANCE DATA SHOWN WAS DETERMINED UNDER THE FOLLOWING CONDITIONS:

LINE VOLTAGE @ 60 Hz. 230V OR 460V FOR 3 PHASE UNITS. 115V OR 230V FOR 1 PHASE UNITS.

LINE VOLTAGE @ 50 Hz. 220V FOR 3 PHASE OR 1 PHASE UNITS.

UNITS IN A TEMPERATURE STABLE CONDITION.

DELIVERY MEASUREMENTS MADE WITH OUTPUT PORT THROTTLED.

SUCTION MEASUREMENTS MADE WITH INPUT PORT THROTTLED.

TEST CONDITIONS: INLET AIR DENSITY @ 0.075 lbs. per cu. ft. [20°C (68°F), 29.92" Hg (14.7 PSIA)].

NORMAL PERFORMANCE VARIATIONS ON THE RESISTANCE CURVE WITHIN ±10% OF SUPPLIED DATA CAN BE EXPECTED.

* DENOTES RECOMMENDED MAXIMUM DUTY

Product Dimensions inches/mm

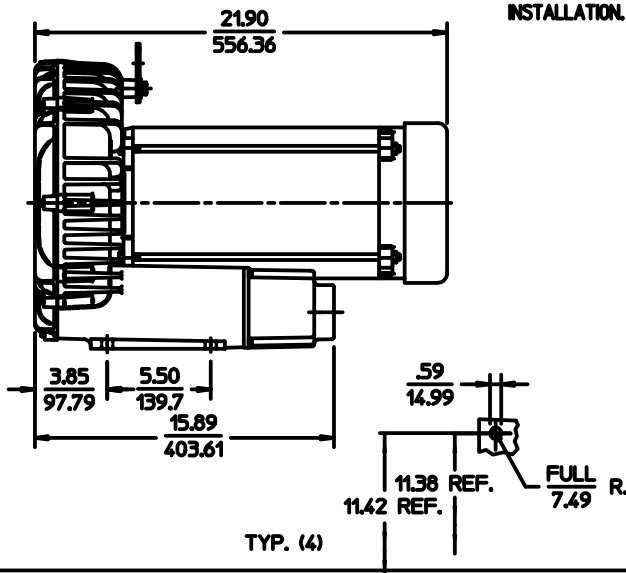

LIFTING PLATE CAN BE TURNED OR REMOVED AFTER BLOWER INSTALLATION.

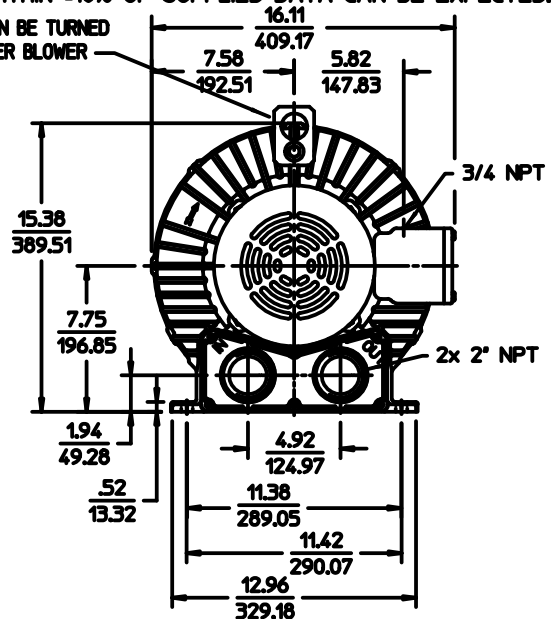

TYP. (4)