

# DRY SPRINKLER COMPRESSOR

## RISER & TANK MOUNT

920 up to 4200 GALLON CAPACITY

# GAST®



120R-200S

*The highest air flow in its class for greater system gallon capacity available in two space saving options*



120R-200T

SCAN FOR PRODUCT  
INFORMATION PAGE



**GAST MANUFACTURING, INC.**

A Unit of IDEX Corporation  
2300 M-139 Highway, Benton Harbor, MI 49022  
Office: 941-416-0252 | Tech: 269-934-1296

[WWW.GASTMFG.COM](http://WWW.GASTMFG.COM)

Copyright © IDEX Corporation 2021. Gast is a unit of IDEX Corporation.

# SUPERIOR COMPRESSOR TECHNOLOGY

Gast **rocking piston** technology leads the way for dry sprinkler compressors in many ways. Our **U.S. based design and manufacturing** features highly engineered cup seal materials for industry leading compressor life, industrial grade shock mounts for **low vibration**, and the highest air flow on the market in this 2 horsepower class. Oil-less operation means **lower maintenance** and this twin-cylinder design has no separate drive belts like some lubricated compressors. Two options are available with riser mount and 20-gallon stationary tank mount that **cover a wide range of sprinkler system sizes**.

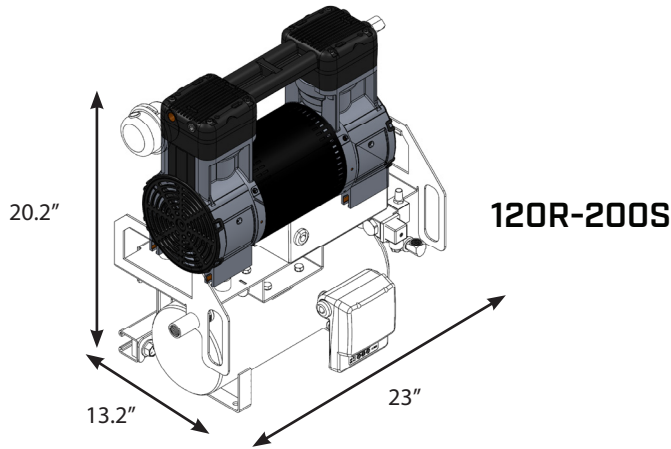

## SPACE SAVING VERTICAL TANK

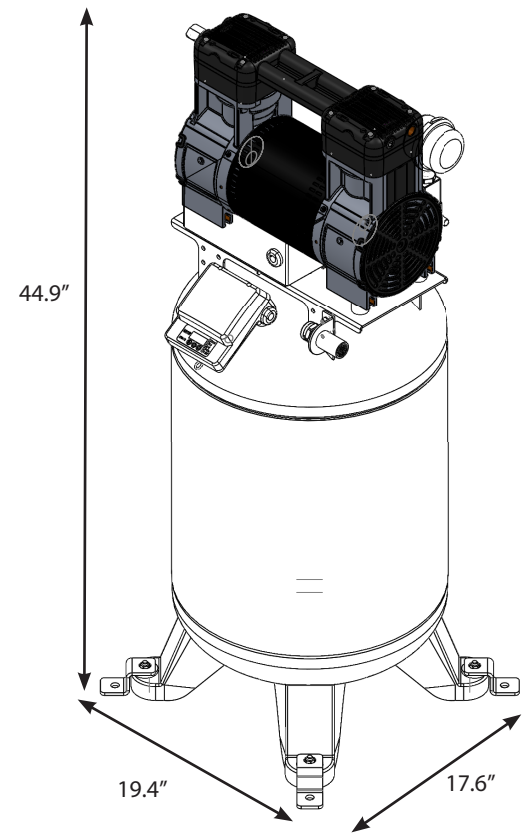

## TIME SAVING RISER MOUNT INSTALLATION

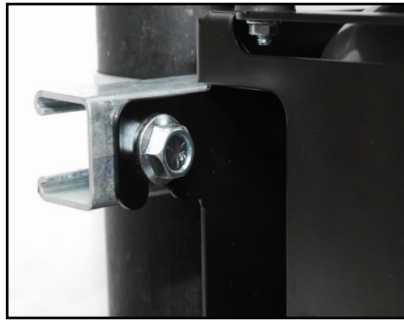
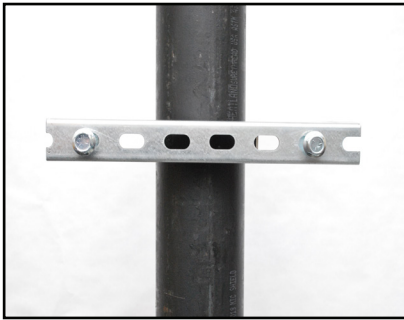

## TECHNICAL DATA AND SPECIFICATIONS

		120R-200S	120R-200T
Voltage	VAC	208-240/ 220-230	208-240/ 220-230
Frequency	HZ	60/50 (single phase)	60/50 (single phase)
System Capacity, 40 psi in 30 min	gallons	921/792	940/804
Current	amps	10/8	10/8
Weight	lbs	94	128
Noise Level	dB(A)	81	81
Dimensions [LxWxH]	in	20.2 x 13.2 x 23	19.4 x 17.6 x 44.9
Motor	HP	2	2
Max Pressure	psi	125	125
Tank Size	gallons	2	20